

**Ersatzteile-Liste  
Parts List  
Catalogo Ricambi**

**Nr. 407  
No.**

**Motor Type  
Engine Type  
Motore Tipo**

**126 GS  
126 MC**

**Ausgabe  
Edition  
Edizione 1982**



**BOMBARDIER-ROTAX GMBH  
MOTORENFABRIK**

**A-4623 Gunkskirchen – Austria  
Telefon: (0 72 46) 271-0\*, Telex: 25 546 bomrot a  
Telegrammadresse: Bombrotax Gunkskirchen**

Inhaltsverzeichnis / Table of Contents / Indice dei Capitoli

---

Seite  
Page  
Pagina

---

- 3 Gehäuse  
Crankcase  
Carter Motore
- 7 Kurbelwelle, Kolben, Zylinder, Zylinderkopf  
Crankshaft, Piston, Cylinder, Cylinder Head  
Albero Motore, Pistone, Cilindro, Testa Cilindro
- 11 Zünderdeckel, Kupplungsdeckel  
Magneto Cover, Clutch Cover  
Coperchio Volano, Coperchio Frizione
- 15 MOTOPLAT-Magnetzünder-Generator für GS  
MOTOPLAT Magneto-Generator for GS  
Volano MOTOPLAT per GS
- 17 MOTOPLAT-Magnetzünder für MC  
MOTOPLAT Ignition Unit for MC  
Volano MOTOPLAT per MC
- 19 Kupplung, Kickstarter  
Clutch, Kick Start  
Frizione, Messa in Moto
- 23 Getriebe  
Transmission  
Trasmissione
- 29 Vergaser  
Carburetor  
Carburatore
- 33 Werkzeug  
Tools  
Attrezzi

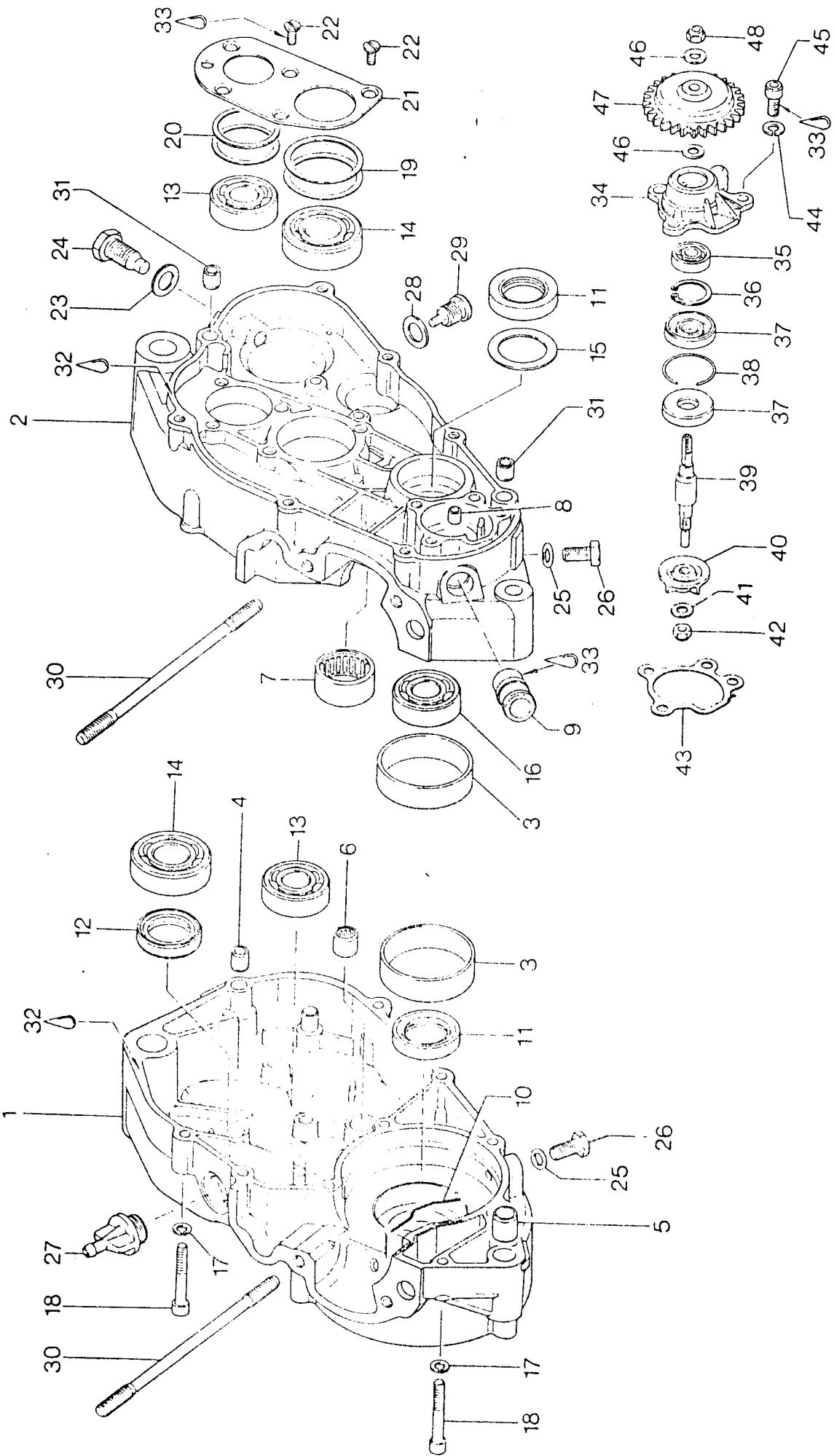

Gehäuse / Crankcase / Carter Motore

Bild Nr. Ill. No. Ill. N.	Teile-Nr. Part No. Codice	B e z e i c h n u n g D e s c r i p t i o n D e s c r i z i o n e	Stück Qty Qtà
1 - 10	292 613	Gehäuse kpl. / crankcase assy. / coppia carter motore . . . . .	1
3	260 395	Gehäusering / ring, crankcase / anello teflon . . . . .	2
4	229 140	Paßhülse 9,8 Ø x 10 / dowel, locating / spina carter . . . . .	1
5	229 160	Paßhülse 13,8 Ø x 15 / dowel, locating / spina carter . . . . .	1
6	232 030	Nadelhülse 10x14x12 / needle bushing / gabbia a rulli . . . . .	1
7	232 040	Nadelhülse 28x35x16 / needle bushing / gabbia a rulli . . . . .	1
8	233 520	Lagerbüchse / sleeve / bussola . . . . .	1
9	224 260	Anlaufrohr / tube / tubo . . . . .	1
10	831 015	Dichtschnur / sealing string / cordoncino guarnizione . . . . .	1
11	230 395	Wellendichtring 25x40x7 / oil seal / corteco . . . . .	2
12	230 421	Wellendichtring 28x38x7 / oil seal / corteco . . . . .	1
13	932 030	Rillenkugellager 6203 / ball bearing / cuscinetto . . . . .	2
14	932 432	Rillenkugellager 6204 / ball bearing / cuscinetto . . . . .	2
15	427 230	Anlaufscheibe 28,2/39,5/1,0 / washer / spessore . . . . .	1
16	232 850	Rillenkugellager 6203 / ball bearing / cuscinetto . . . . .	1
17	945 751	Federring A6 / lock washer 6 / rondella grower 6 . . . . .	11
18	241 816	Zylinderschraube M6 x 40 / screw, allen head / vite a testa cil. . . . .	11

Bild Nr. Ill. No. Ill. N.	Teile Nr. Part No. Codice	B e z e i c h n u n g D e s c r i p t i o n D e s c r i z i o n e	Stück Qty Qtà
19	227 610	Ausgleichscheibe 0,5 mm / shim 0,5 mm, transmission clutch shaft bearing / spessore albero primario mm. 0,5 . . . . .	nach Bedarf as requ. a richiesta
	227 611	Ausgleichscheibe 0,3 mm / shim 0,3 mm, transmission clutch shaft bearing / spessore albero primario mm. 0,3 . . . . .	nach Bedarf as requ. a richiesta
	227 612	Ausgleichscheibe 0,1 mm / shim 0,1 mm, transmission clutch shaft bearing / spessore albero primario mm. 0,1 . . . . .	nach Bedarf as requ. a richiesta
20	227 520	Ausgleichscheibe 0,5 mm / shim 0,5 mm, transmission main shaft bearing / spessore albero sekundario mm. 0,5 . . . . .	nach Bedarf as requ. a richiesta
	227 521	Ausgleichscheibe 0,3 mm / shim 0,3 mm, transmission main shaft bearing / spessore albero sekundario mm. 0,3 . . . . .	nach Bedarf as requ. a richiesta
	227 522	Ausgleichscheibe 0,1 mm / shim 0,1 mm, transmission main shaft bearing / spessore albero sekundario mm. 0,1 . . . . .	nach Bedarf as requ. a richiesta
21	227 555	Halteblech / retaining plate, trans- mission bearings / piastra fissaggio cuscinetti . . . . .	1
22	940 315	Senkschraube M5 x 12 / screw, counter- sunk slot head / vite fissaggio piastra cuscinetto . . . . .	5
23	650 040	Dichtungsscheibe / gasket ring / rondella tappo scarico olio . . . . .	1
24	241 775	Ausrückschraube M12 / screw, kick starter stop / fermo messa in moto . . . . .	1
25	950 141	Dichtring C8 x 14 / gasket ring / rondella tappo spurgo carter . . . . .	2
26	940 580	Sechskantschraube M8 x 16 / screw, hex. head, crankcase drain / vite a testa esagone . . . . .	2
27	241 920	Entlüfterschraube M18 x 1,5 / oil filler cap / tappo immissione olio . . . . .	1
28	650 040	Dichtungsscheibe / gasket ring / rondella tappo scarico olio . . . . .	1
29	241 781	Magnetschraube M12 x 1,5 / plug, magnetic drain / tappo scarico olio . . . . .	1

Bild Nr. Ill. No. Ill. N.	Teile Nr. Part No. Codice	B e z e i c h n u n g D e s c r i p t i o n D e s c r i z i o n e	Stück Qty Qtà
30	940 381	Stiftschraube M8 x 147,5 / stud, cylinder / colonnetta cilindro . . . . .	4
31	229 140	Paßhülse 9,8 Ø x 10 / dowel, locating / spina carter . . . . .	2
32	899 682	Flanschdichtung Spezial 50 ccm LOCTITE weiß / LOCTITE sealing material, white 50 c.c. / flacone Loctite bianca 50 cc. . . . .	nach Bedarf as requ. a richiesta
33	899 786	Schraubensicherungsmittel 6 ccm, LOCTITE blau / means of securing, LOCTITE blue 6 c.c. / flacone Loctite blu 6 cc. . . . .	nach Bedarf as requ. a richiesta
34 - 42	292 950	Wasserpumpe kpl. / water pump assy. / pompa acqua . . . . .	1
34	222 040	Wasserpumpengehäuse / water pump housing / corpo pompa acqua . . . . .	1
35	932 770	Rillenkugellager 608 / ball bearing / cuscinetto . . . . .	1
36	245 480	Sicherungsring 22 x 1 / locking ring / seger . . . . .	1
37	831 740	Wellendichtring 12x30x6 / oil seal / corteco . . . . .	2
38	827 530	Stützring / securing ring / anello sicurezza . . . . .	1
39	237 680	Pumpenwelle / pump shaft / albero pompa . . . . .	1
40	222 050	Laufrad / water pump wheel / girante . . . . .	1
41	927 946	Scheibe 6,2 / washer / rondella . . . . .	1
42	842 040	Sicherungsmutter M6 / locking nut / dado . . . . .	1
43	230 970	Dichtung / gasket / guarnizione . . . . .	1
44	945 751	Federring A6 / lock washer 6 / rondella grower 6 . . . . .	3
45	840 390	Zylinderschraube M6 x 14 / cyl. screw / vite a testa cil. . . . .	3
46	244 211	Scheibe 6,4 / washer / rondella . . . . .	2
47	235 870	Pumpenrad 28 Z. / pump gear / ingranaggio pompa . . . . .	1
48	842 040	Sicherungsmutter M6 / locking nut / dado . . . . .	1

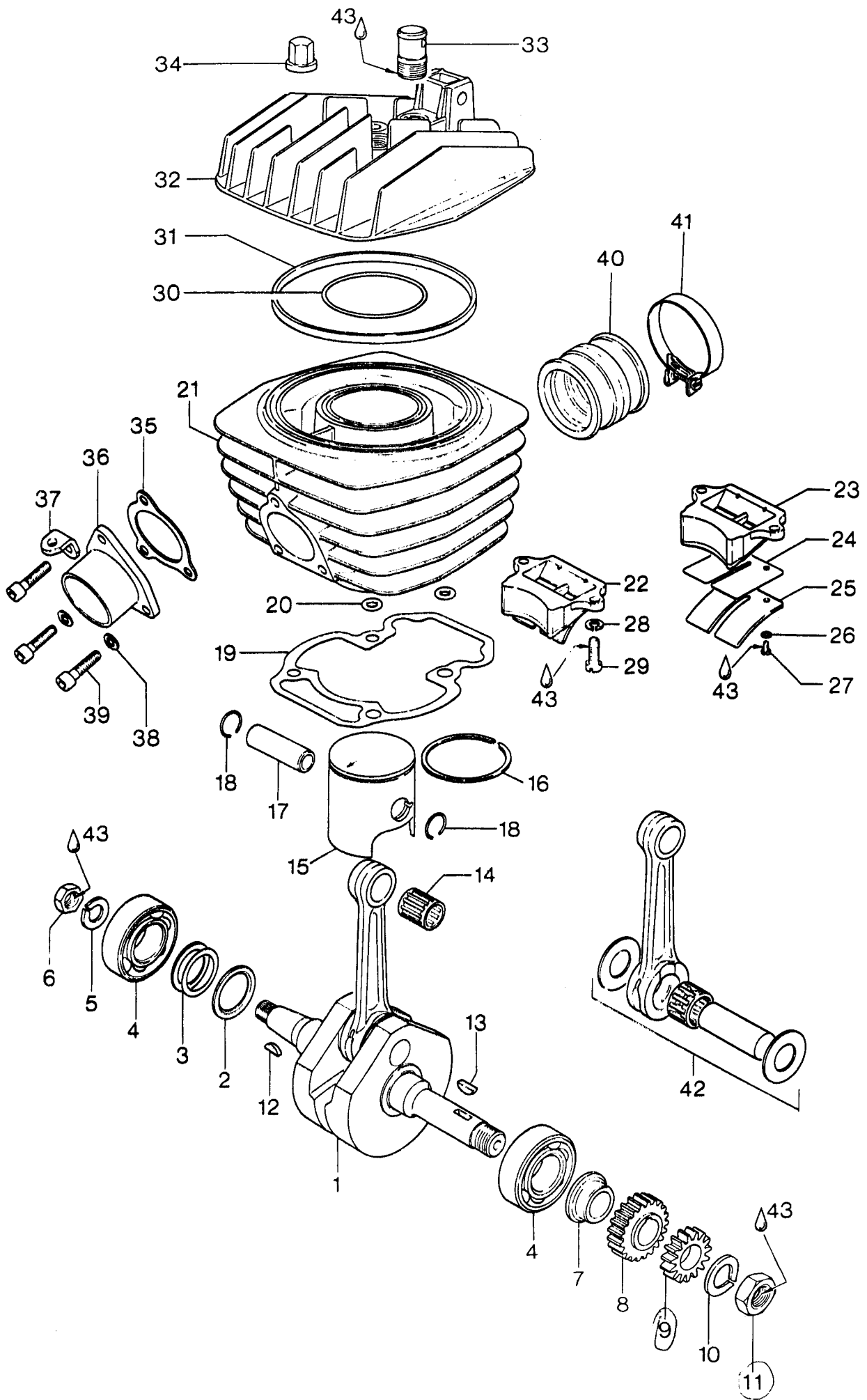

Kurbelwelle, Kolben, Zylinder, Zylinderkopf  
Crankshaft, Piston, Cylinder, Cylinder Head  
Albero Motore, Pistone, Cilindro, Testa Cilindro

---

Bild Nr. Ill. No. Ill. N.	Teile Nr. Part No. Codice	B e z e i c h n u n g D e s c r i p t i o n D e s c r i z i o n e	Stück Qty Qtà
1	292 620	Kurbelwelle kpl. / crankshaft assy. / albero motore compl. . . . .	1
2	827 720	Radiusscheibe 25,8/37/1 / distance ring, magneto side / distanziale albero motore .	1
3	944 470	Ausgleichscheibe 0,2 mm / shim 0,2 mm, crankshaft magneto / spessore albero motore mm. 0,2 . . . . .	nach Bed as req a richie
	944 471	Ausgleichscheibe 0,3 mm / shim 0,3 mm, crankshaft magneto / spessore albero motore mm. 0,3 . . . . .	nach Bed as req a richie
	944 472	Ausgleichscheibe 0,5 mm / shim 0,5 mm, crankshaft magneto / spessore albero motore mm. 0,5 . . . . .	nach Bed as req a richie
	944 474	Ausgleichscheibe 0,1 mm / shim 0,1 mm, crankshaft magneto / spessore albero motore mm. 0,1 . . . . .	nach Bed as req a richie
4	232 761	Rillenkugellager 6205 / ball bearing, crankshaft, magneto side / cuscinetto banco destro . . . . .	2
5	945 754	Federring A12 / lock washer 12 / rondella grower 12 . . . . .	1
6	642 051	Sechskantmutter M12 x 1 / hex. nut, crankshaft magneto side / dado fissaggio volano . . . . .	1
7	247 460	Stufenhülse / sleeve / bussola . . . . .	1
8	292 970	Primärtrieb kpl. (nur Antriebsrad und Kupplungskorb gemeinsam austauschen!) / drive gear with clutch drum assy. (re- place only drive gear with clutch drum assy.!) / ingranaggio albero motore (cambiare solo insieme ingranaggio con campana frizione!) . . . . .	1
9	235 860	Pumpenritzel 15 Z. / pump gear 15 t. / ingranaggio pompa 15 D . . . . .	1
10	945 756	Federring A16 / lock washer 16 / rondella grower 16 . . . . .	1



Bild Nr. Ill. No. Ill. N.	Teile Nr. Part No. Codice	B e z e i c h n u n g D e s c r i p t i o n D e s c r i z i o n e	Stück Qty Qtà
11	242 570	Sechskantmutter M16 x 1,5 / hex. nut, crankshaft, clutch side / dado fissaggio ingranaggio albero motore . . . . .	1
12	246 011	Scheibefeder 3 x 5 / key, Woodruff, crankshaft, magneto side / chiavella destra albero motore . . . . .	1
13	246 570	Scheibefeder 4 x 5 / key, Woodruff, crankshaft, clutch side / chiavella sinistra albero motore . . . . .	1
14	932 027	Kolbenbolzenkäfig / needle bearing, piston pin / gabbia a rulli spinotto . . .	1
15,16,	292 650	Kolben kpl. 54,0 Ø m. Ring, Standard / piston assy. 54,0 mm w. ring, standard / pistone 54,0 mm con segmento . . . . .	1
16	215 270	Rechteckring 54,0 Ø, Standard / rectangular ring 54,0 mm, standard / segmento R 54,0 mm	1
17	216 125	Kolbenbolzen / piston pin / spinotto . . .	1
18	945 635	Nullhakenring 15 / circlip, piston pin / seger spinotto . . . . .	2
19	230 955	Dichtung für Zylinderflansch / gasket, cylinder base / guarnizione cilindro . . .	1
20	230 260	O-Ring / O-ring / anello . . . . .	4
21	213 381	Zylinder / cylinder / cilindro . . . . .	1
22	224 295	Ventilträger kpl. / reed valve assy. / porta valvola completa . . . . .	1
23	224 292	Ventilträger / reed valve / porta valvola .	1
24	224 270	Blattventil / reed pedal / valvola a lamelle . . . . .	1
25	224 280	Ventilanschlag / reed pedal stop / arresto valvola . . . . .	1
26	245 090	Federring A3 / lock washer 3 / rondella grower 3 . . . . .	2
27	240 350	Linsenschraube M3 x 6 / screw / vite . . .	2
28	945 751	Federring A6 / lock washer 6 / rondella grower 6 . . . . .	2
29	940 085	Zylinderschraube M6 x 16 / cyl. screw / vite a testa cil. . . . .	2

Bild Nr. Ill. No. Ill. N.	Teile Nr. Part No. Codice	B e z e i c h n u n g D e s c r i p t i o n D e s c r i z i o n e	Stück Qty Qtà
30	831 780	O-Ring 50-2 / O-ring / anello . . . . .	1
31	230 960	Schlauchring 122-127-5 / sealing ring / guarnizione testa . . . . .	1
32	213 390	Zylinderkopf / cylinder head / testa . .	1
33	224 090	Ablaufrohr / tube / tuba . . . . .	1
34	842 471	Bundhutmutter M8 / cup nut / dado fissaggio testa . . . . .	4
35	230 930	Dichtung / gasket, exhaust socket / guarnizione flangia scarico . . . . .	1
36	273 750	Auspuffstutzen / exhaust socket assy. / flangia scarico . . . . .	1
37	224 250	Federeinhängung / spring bracket / coprigiunto . . . . .	1
38	945 751	Federring A6 / lock washer 6 / rondella grower 6 . . . . .	2
39	840 400	Zylinderschraube M6 x 22 / cyl. screw, exhaust socket / brugola fissaggio flangia . . . . .	3
40	867 480	Vergaserstutzen kpl. / rubber flange assy. / flangia carburatore compl. . . .	1
41	251 850	Schlauchselle 51 kpl. / hose clamp 51 assy. / fascetta manicotto carburatore	2
42	292 739	Kurbelwellen-Reparatursatz / crankshaft repair set / gruppo biella compl. . . . .	1
43	899 786	Schraubensicherungsmittel 6 ccm, LOCTITE blau / means of securing, LOCTITE blue 6 c.c. / flacone Loctite blu 6 cc. . . .	nach Bedarf as requ. a richiesta

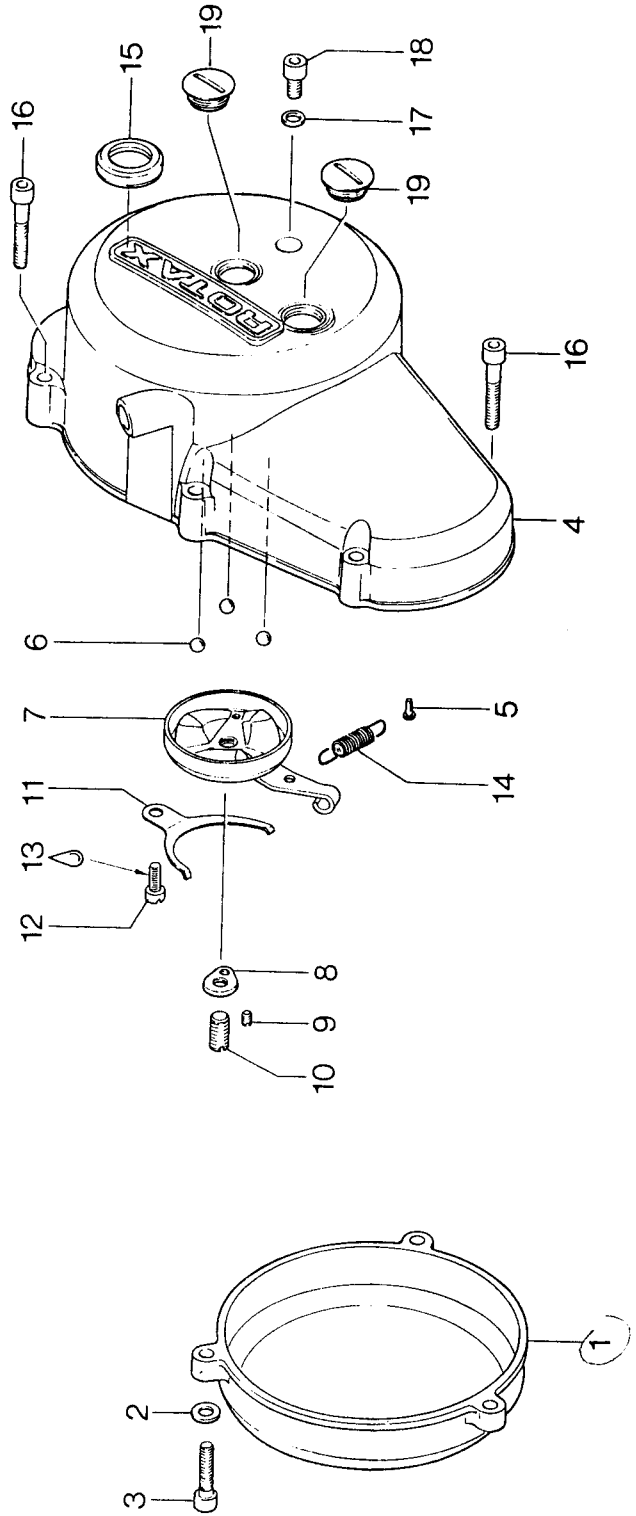
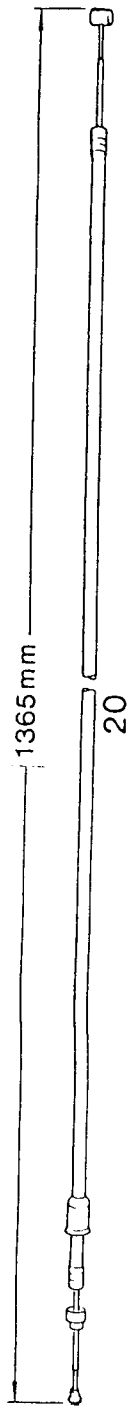

Zünderdeckel, Kupplungsdeckel  
 Magneto Cover, Clutch Cover  
 Coperchio Volano, Coperchio Frizione

Bild Nr. Ill. No. Ill. N.	Teile Nr. Part No. Codice	B e z e i c h n u n g D e s c r i p t i o n D e s c r i z i o n e	Stück Qty Qtà
1	212 660	Zünderdeckel / magneto cover / coperchio volano . . . . .	1
2	927 946	Scheibe 6,2 / washer / ranella . . . . .	3
3	840 861	Zylinderschraube M6 x 25 / cyl. screw / vite a testa cil. . . . .	3
4,5,	212 651	Kupplungsdeckel kpl. / clutch cover assy. / coperchio frizione compl. . . . .	1
5	949 030	Halbrundkerbnagel 3 x 8 / drive pin / spina . . . . .	1
6	232 440	Kugel 7/32" / ball / sfere . . . . .	3
7	259 795	Ausrückteller / cam assy., clutch release / chiocciola frizione . . . . .	1
8	259 630	Fixierplatte / plate, clutch adjustment, locking / fermo vite registro frizione . . . . .	1
9	241 791	Gewindestift M8 x 15 / screw, clutch adjustment / vite registro frizione . . . . .	1
10	241 795	Gewindestift M4 x 6 / screw, clutch adjustment / grano fermo registro frizione . . . . .	1
11	239 660	Blattfeder / spring, clutch cam retaining / innesto frizione . . . . .	1
12	240 560	Zylinderschraube M5 x 12 / screw, slot head / vite fissaggio innesto chiocciola . . . . .	1
13	899 786	Schraubensicherungsmittel 6 ccm, LOCTITE blau / means of securing, LOCTITE blue 6 c.c. / flacone Loctite blu 6 cc. . . . .	nach Bedarf as requ. asrichiesta
14	239 630	Zugfeder / spring, clutch cam return / molla chiocciola frizione . . . . .	1
15	230 355	Wellendichtring 20x28x6 / seal, kick start shaft / corteco messa in moto . . . . .	1
16	241 811	Zylinderschraube M6 x 35 / screw, allen head / vite fissaggio carter frizione . . . . .	8

Bild Nr. Ill. No. Ill. N.	Teile Nr. Part No. Codice	B e z e i c h n u n g D e s c r i p t i o n D e s c r i z i o n e	Stück- Qty Qtà
17	830 890	Dichtring / gasket, oil level plug / rondella brugola livello olio . . . . .	1
18	840 370	Zylinderschraube M6 x 11,5 / plug, oil level / brugola livello olio . . . . .	1
19	241 800	Verschlußschraube M18 x 1,5 / plug, adjustment / tappo plastica carter frizione	2
20	297 445	Kupplungsseilzug kpl. / clutch cable / trasmissione frizione . . . . .	1

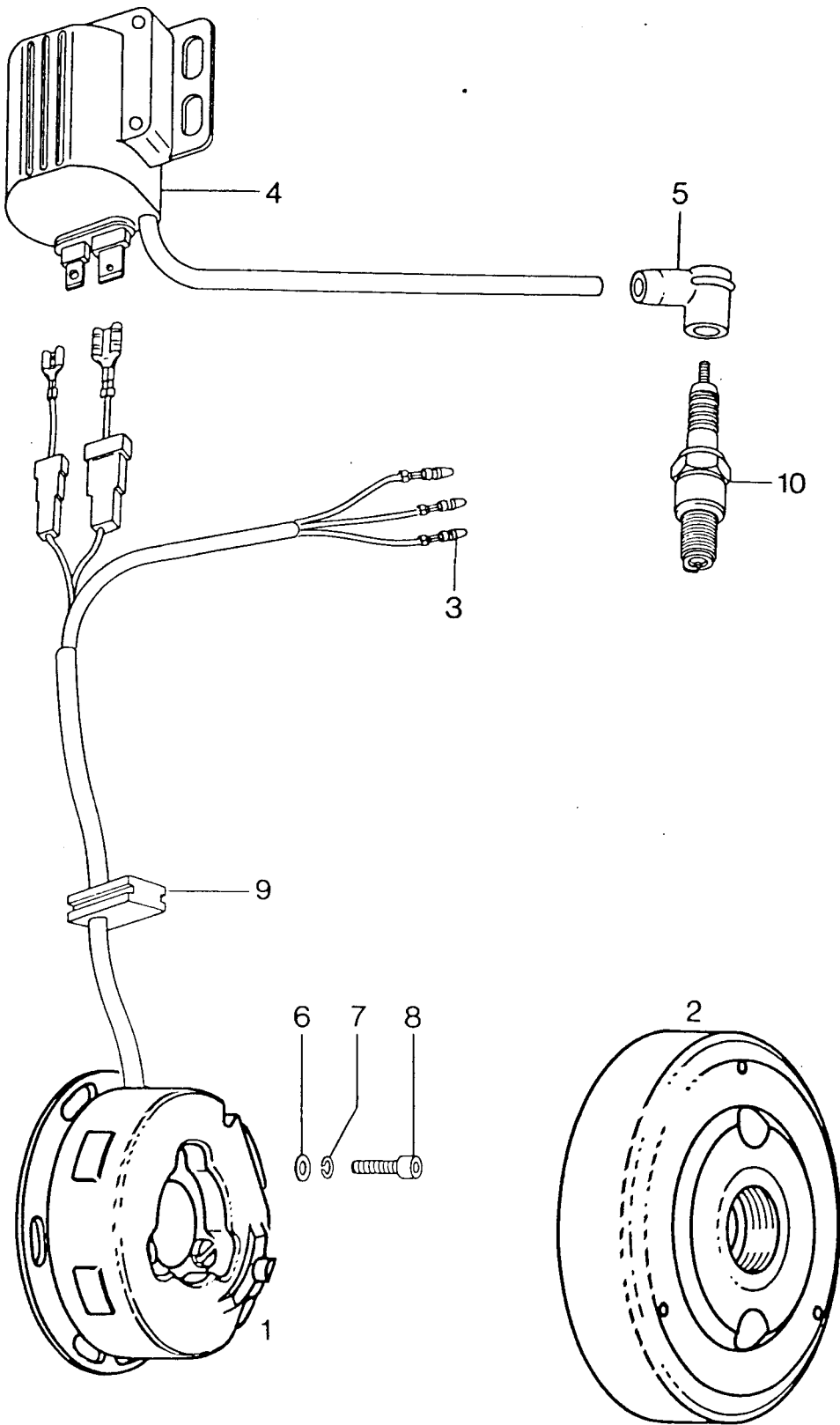

MOTOPLAT-Magnetzünder-Generator für GS  
MOTOPLAT Magneto-Generator for GS  
Volano MOTOPLAT per GS

Bild Nr. Ill. No. Ill. N.	Teile-Nr. Part No. Codice	B e z e i c h n u n g D e s c r i p t i o n D e s c r i z i o n e	Stück Qty Qtà
1,2,3,	292 631	MOTOPLAT-Magnetzünder-Generator kpl. 6V 35/21/5W / MOTOPLAT magneto generator assy. / volano MOTOPLAT compl. . . . .	1
3	964 062	Steckerstift / contact pin / spina a baionetta . . . . .	3
4	264 830	Zündspule / ignition coil / bobina accensione . . . . .	1
5	865 200	Zündleistungsstecker / park plug protector / cappuccio candela . . . . .	1
6	244 072	Scheibe 4,3 / washer / rondella brugola fissaggio piatto . . . . .	3
7	945 758	Federring A4 / lock washer 4 / rondella grower 4 . . . . .	3
8	940 470	Zylinderschraube M4 x 16 / screw, allen head / vite fissaggio piatto volano. . .	3
9	260 630	Leitungstülle / cable grommet / gommina filo volano . . . . .	1
10	899 576	Zündkerze W300 T2 (W2C) / spark plug W300 T2 (W2C) / candella W300 T2 (W2C) .	1

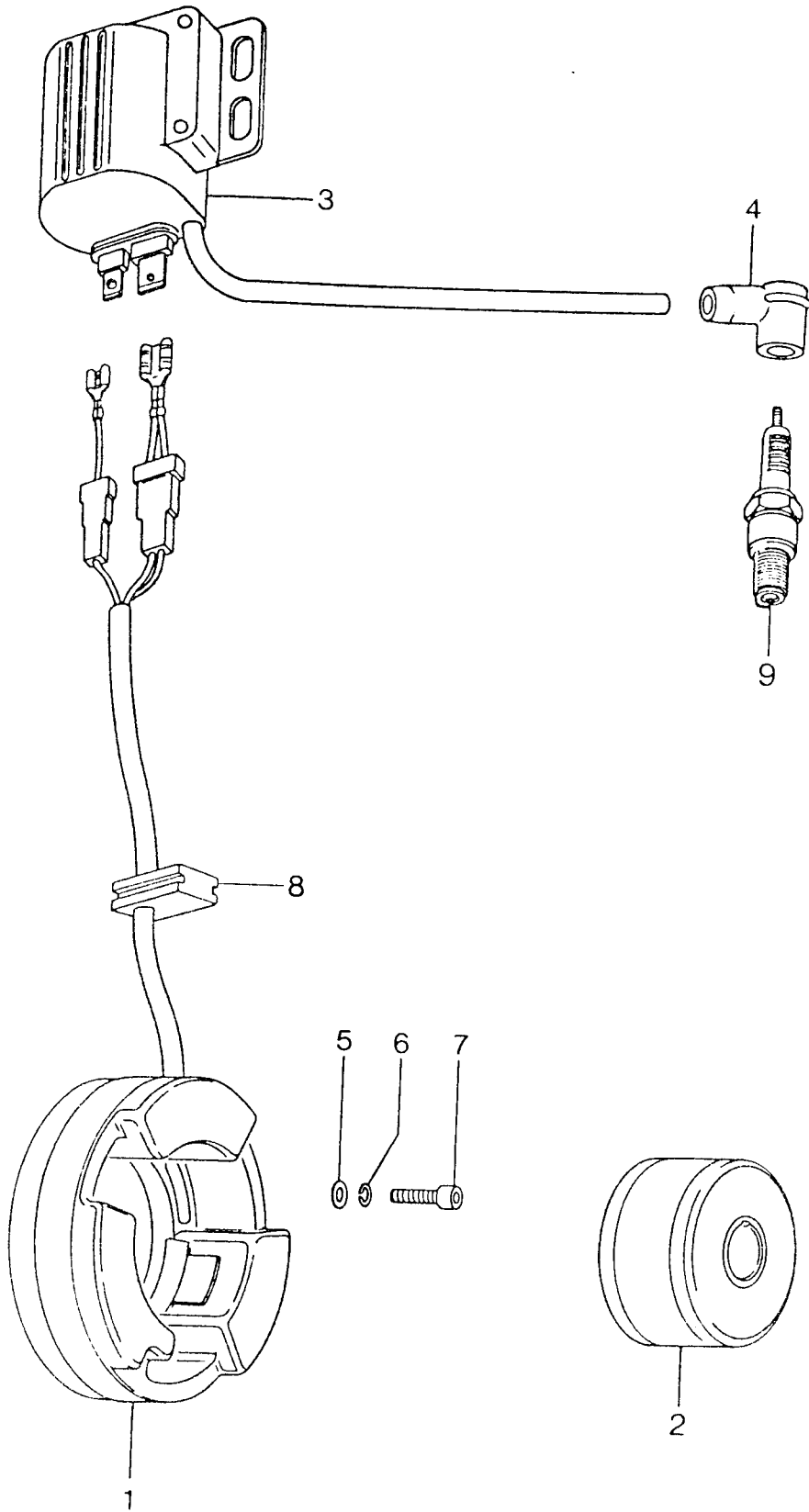



MOTOPLAT-Magnetzünder für MC  
MOTOPLAT Ignition Unit for MC  
Volano MOTOPLAT per MC

Bild Nr. Ill. No. Ill. N.	Teile-Nr. Part. No. Codice	B e z e i c h n u n g D e s c r i p t i o n D e s c r i z i o n e	Stück Qty Qtà
1,2,	292 641	MOTOPLAT-Magnetzünder kpl. / MOTOPLAT ignition unit assy. / volano MOTOPLAT compl. . . . .	1
3	264 830	Zündspule / ignition coil / bobina accensione . . . . .	1
4	865 200	Zündleistungsstecker / spark plug protector / cappuccio candela . . . . .	1
5	927 570	Scheibe 5,3 / washer 5,3 / rondella brugola fissaggio piatto . . . . .	3
6	945 750	Federring A5 / lock washer 5 / rondella grower 5 . . . . .	3
7	240 180	Zylinderschraube M5 x 20 / screw, allen head / vite fissaggio piatto volano . .	3
8	260 630	Leitungsstülle / cable grommet / gommina filo volano . . . . .	1
9	899 576	Zündkerze W300 T2 (W2C) / spark plug W300 T2 (W2C) / candela W300 T2 (W2C). .	1

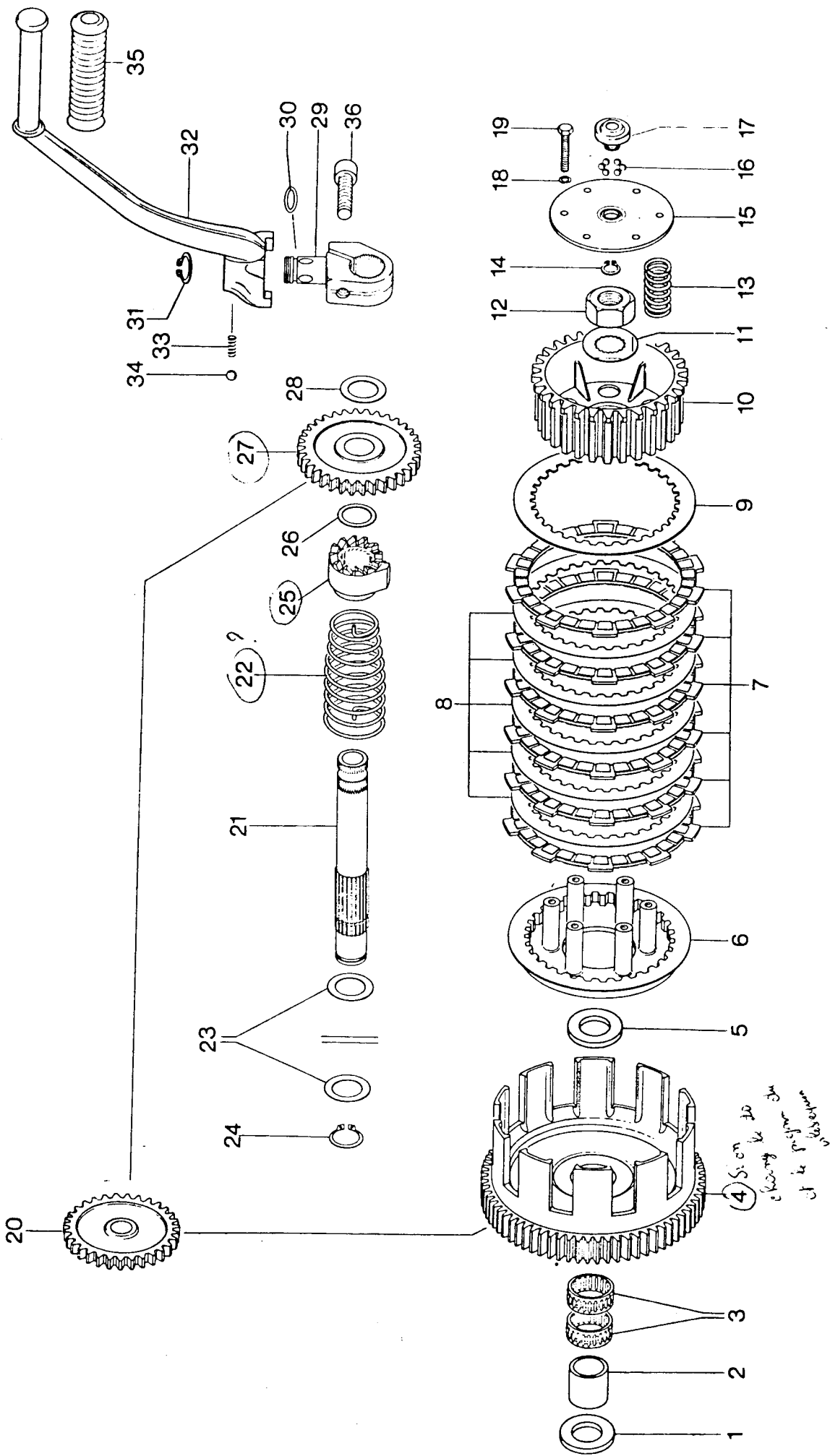

Kupplung, Kickstarter  
Clutch, Kick Start  
Frizione, Messa in Moto

Bild Nr. Ill. No. Ill. N.	Teile Nr. Part No. Codice	B e z e i c h n u n g D e s c r i p t i o n D e s c r i z i o n e	Stück Qty Qtà
1	227 600	Anlaufscheibe 20,2/35/3 / thrust washer, clutch drum / spessore campana frizione . . .	1
2	232 700	Innenring / inner race, clutch drum / boccola campana frizione . . . . .	1
3	232 650	Nadelkäfig / needle bearing, clutch drum / gabbia a rulli campana frizione . . . . .	2
4	292 970	Primärtrieb kpl. (nur Antriebsrad mit Kupplungskorb gemeinsam austauschen!) / drive gear with clutch drum assy. (replace only drive gear with clutch drum assy.!) / campana frizione (cambiare solo insieme ingranaggio con campana frizione!) . . . . .	1
5	227 600	Anlaufscheibe 20,2/35/3 / thrust washer, clutch drum / spessore campana frizione . . .	1
6	259 570	Stützteller / plate, clutch, inner pressure / tamburello . . . . .	1
7	259 560	Außenlamelle / plate, clutch friction / disco frizione guarnito . . . . .	6
8	259 557	Innenlamelle / plate, clutch, outer pressure / mm. 1,0 disco frizione ferro . . .	5
9	259 555	Stützlammelle / plate, clutch, outer pressure / mm. 1,5 disco frizione ferro . . .	1
10	259 545	Mitnehmer / clutch hub / tamburello frizione . . . . .	1
11	245 320	Sicherungsblech NA20 / washer, transmission shaft locking / rondella fissaggio dado frizione . . . . .	1
12	242 605	Sechskantmutter M18 x 1,5 / hex. nut / dado frizione . . . . .	1
13	239 625	Kupplungsfeder (Federn nur satzweise wechseln!) / spring, clutch (change springs only setwise!) / molla frizione (cambiare solo tutta la serie!) . . . . .	6

Bild Nr. Ill. No. Ill. N.	Teile Nr. Part No. Codice	B e z e i c h n u n g D e s c r i p t i o n D e s c r i z i o n e	Stück Qty Qtà
14 - 17	259 596	Druckplatte kpl. / plate, clutch spring retaining with hub assy. / piattello compl. frizione . . . . .	1
14	245 330	Sicherungsring 10 x 1 / snapring / seger piattello frizione . . . . .	1
15	259 590	Druckplatte / plate, clutch spring retaining / piattello . . . . .	1
16	932 990	Kugel 5/32" / ball / sfere piattello . . . . .	12
17	259 705	Druckpilz / hub, clutch spring retaining / cuscinetto piattello . . . . .	1
18	945 750	Federring A5 / lock washer 5 / rondella grower 5 fissaggio piattello frizione . . . . .	6
19	241 770	Sechskantschraube M5 x 25 / screw, hex. head / vite fissaggio piattello frizione . . . . .	6
20	235 205	Zwischenrad kpl. / gear, kick start idler / ingranaggio intermedio messa in moto . . . . .	1
21	237 426	Starterwelle / kick start shaft / albero messa in moto . . . . .	1
22	239 760	Kickstarterfeder / spring, kick start return / molla di richiamo messa in moto . . . . .	1
23	944 468	Anlaufscheibe 20,5/30/1 / thrust washer / spessore messa in moto . . . . .	2
24	945 660	Sicherungsring 20 x 1,2 / snapring, kick start shaft / seger messa in moto . . . . .	1
25	228 185	Sperrad / ratchet gear, kick start / innesto messa in moto . . . . .	1
26	227 480	Anlaufscheibe 20,2/25,5/1 / thrust washer, kick gear / spessore albero messa in moto . . . . .	1
27	235 855	Starterrad kpl. / gear, kick start drive / ingranaggio messa in moto . . . . .	1
28	944 468	Anlaufscheibe 20,5/30/1 / thrust washer, kick start / spessore ingranaggio messa in moto . . . . .	1
29 - 35	248 870	Kickstarterhebel kpl. / lever assy., kick start / pedale messa in moto . . . . .	1

Bild Nr.	Teile Nr.	B e z e i c h n u n g	Stück
Ill. No.	Part No.	D e s c r i p t i o n	Qty
Ill. N.	Codice	D e s c r i z i o n e	Qtà
29 - 31	248 809	Kickstarternabe kpl. / hub assy., kick start / parte inferiore messa in moto . . .	1
30	230 461	O-Ring / O-ring / anello snodo messa in moto . . . . .	1
31	945 845	Sicherungsring 15 x 1,5 / snapring, kick start lever / seger messa in moto . . . . .	1
32	248 794	Kickstarterhebel / lever, kick start / parte superiore messa in moto . . . . .	1
33	239 535	Druckfeder / spring, kick start lever / molla sfera messa in moto . . . . .	1
34	232 440	Kugel 7/32" / ball, kick start lever / sfera messa in moto . . . . .	1
35	260 210	Muffe / rubber sleeve, kick start / gommino pedale messa in moto . . . . .	1
36	840 991	Zylinderschraube M8 x 30 / cyl. screw / vite fissaggio messa in moto . . . . .	1

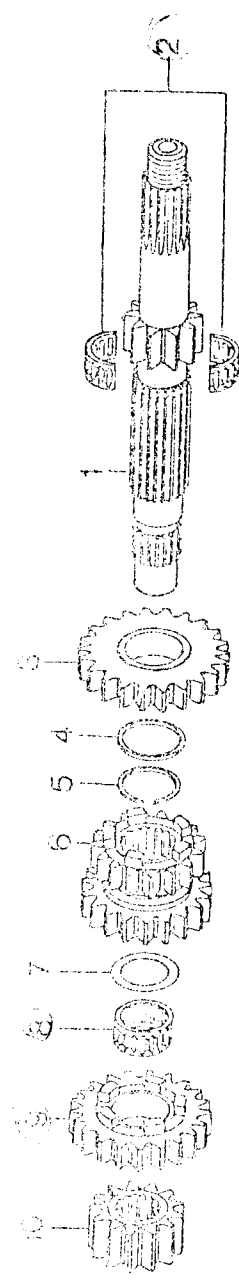
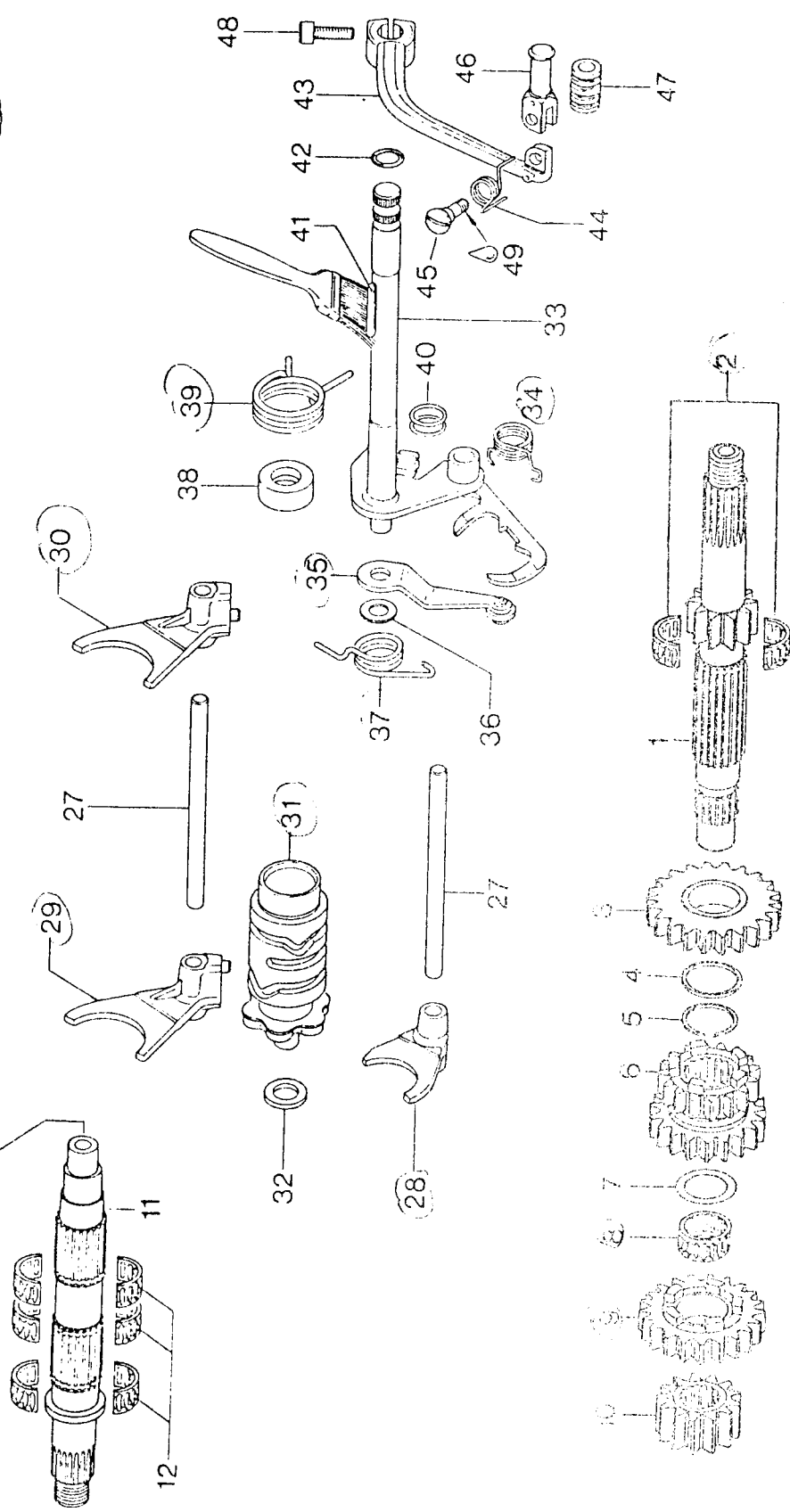
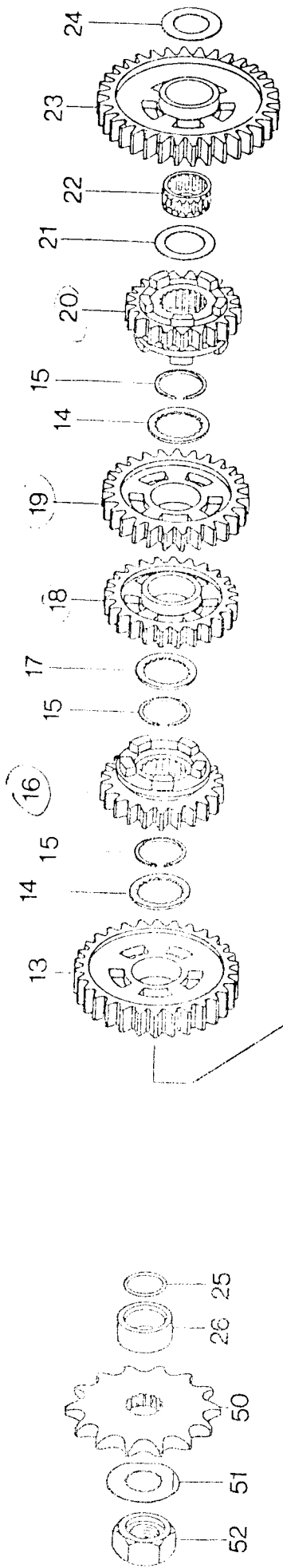

Getriebe / Transmission / Trasmissione

Bild Nr. Ill. No. Ill. N.	Teile Nr. Part No. Codice	B e z e i c h n u n g D e s c r i p t i o n D e s c r i z i o n e	126 GS / 126 MC Stück Qty/Qtà
1 - 25	281 010	Getriebe kpl. / transmission assy. / cambio compl. . . . .	1 -
1 - 25	281 020	Getriebe kpl. / transmission assy. / cambio compl. . . . .	- 1
1	237 467	Vorgelegewelle 12 Z. / clutch shaft / albero primario . . . . .	1 -
1	237 462	Vorgelegewelle 13 Z. / clutch shaft / albero primario . . . . .	- 1
2	232 665	Nadelkäfig / needle bearing assy., clutch shaft / gusci a rulli albero primario . . . . .	1 1
3	235 281	Losrad 23 Z. / gear 6 <sup>th</sup> , clutch shaft / ingranaggio 6 <sup>o</sup> primario . . . .	1 -
3	234 886	Losrad 22 Z. / gear 6 <sup>th</sup> , clutch shaft / ingranaggio 6 <sup>o</sup> primario . . . .	- 1
4	227 470	Anlaufscheibe / thrust washer, clutch shaft / spessore cambio albero primario . . . . .	1 1
5	245 340	Sprengring / snapring, clutch shaft / seger cambio albero primario	1 1
6	234 971	Schaltrad 17/19 Z. / gear 3 <sup>rd</sup> /4 <sup>th</sup> , clutch shaft / ingranaggio 3 <sup>o</sup> -4 <sup>o</sup> primario . . . . .	1 1
7	227 440	Anlaufscheibe / thrust washer, clutch shaft / spessore cambio albero primario . . . . .	1 1
8	232 660	Nadelkäfig / needle bearing 20, clutch shaft / gabbia a rulli albero primario . . . . .	1 1
9	234 866	Losrad 21 Z. / gear 5 <sup>th</sup> , clutch shaft / ingranaggio 5 <sup>o</sup> primario . . . .	1 1
10	235 305	Festrad 14 Z. / gear 2 <sup>nd</sup> , clutch shaft / ingranaggio 2 <sup>o</sup> primario . . . .	1 -
10	234 950	Festrad 15 Z. / gear 2 <sup>nd</sup> , clutch shaft / ingranaggio 2 <sup>o</sup> primario . . . .	- 1

Bild Nr. Ill. No. Ill. N.	Teile Nr. Part No. Codice	B e z e i c h n u n g D e s c r i p t i o n D e s c r i z i o n e	126 GS / 126 MC Stück Qty/Qtà	
11	237 417	Hauptwelle / main shaft / albero secondario . . . . .	1	1
12	232 740	Nadelkäfig / needle bearing 21, main shaft / guscio a rulli albero secondario . . . . .	3	3
13	235 318	Losrad 28 Z. / gear 2nd, main shaft / ingranaggio 2 <sup>o</sup> secondario . . . . .	1	-
13	234 963	Losrad 29 Z. / gear 2nd, main shaft / ingranaggio 2 <sup>o</sup> secondario . . . . .	-	1
14	227 460	Anlaufscheibe / thrust washer, main shaft / spessore cambio albero secondario . . . . .	2	2
15	245 340	Sprengring / snapring, main shaft / seger albero secondario . . . . .	3	3
16	234 878	Schaltrad 23 Z. / gear 5th, main shaft / ingranaggio 5 <sup>o</sup> secondario . . . . .	1	1
17	227 490	Winkelring / angular ring / anello ad angolo . . . . .	1	1
18	234 858	Losrad 25 Z. / gear 4th, main shaft / ingranaggio 4 <sup>o</sup> secondario . . . . .	1	1
19	234 983	Losrad 27 Z. / gear 3rd, main shaft / ingranaggio 3 <sup>o</sup> secondario . . . . .	1	1
20	235 293	Schaltrad 21 Z. / gear 6th, main shaft / ingranaggio 6 <sup>o</sup> secondario . . . . .	1	-
20	234 993	Schaltrad 21 Z. / gear 6th, main shaft / ingranaggio 6 <sup>o</sup> secondario . . . . .	-	1
21	944 468	Anlaufscheibe / thrust washer, main shaft / spessore albero secondario . . . . .	1	1
22	232 660	Nadelkäfig / needle bearing 20, main shaft / gabbia a rulli albero secondario . . . . .	1	1
23	234 948	Losrad 32 Z. / gear 1st, main shaft / ingranaggio 1 <sup>o</sup> secondario . . . . .	1	-
23	234 943	Losrad 31 Z. / gear 1st, main shaft / ingranaggio 1 <sup>o</sup> secondario . . . . .	-	1
24	227 430	Anlaufscheibe / thrust washer, main shaft / spessore albero secondario . . . . .	1	1



Bild Nr. Ill. No. Ill. N.	Teile Nr. Part No. Codice	B e z e i c h n u n g D e s c r i p t i o n D e s c r i z i o n e	126 GS / 126 MC Stück Qty/Qtà
25	230 400	O-Ring / O-ring, main shaft / anello tenuta olio albero secondario . . . . .	1 1
26	247 225	Distanzhülse / spacer, sprocket / corteco albero secondario . . . . .	1 1
27	258 785	Schaltstange / pin, shift fork guide / asta bandieretta . . . . .	2 2
28	258 777	Schaltgabel 5/6. Gang / fork, shifting 5-6 / bandieretta cambio 5 <sup>o</sup> -6 <sup>o</sup> . . . . .	1 1
29	258 767	Schaltgabel 2/4. Gang / fork, shifting 2-4 / bandieretta cambio 2 <sup>o</sup> -4 <sup>o</sup> . . . . .	1 1
30	258 757	Schaltgabel 1/3. Gang / fork, shifting 1-3 / bandieretta cambio 1 <sup>o</sup> -3 <sup>o</sup> . . . . .	1 1
31	258 835	Schaltwalze kpl. / shift drum assy. / desmodromico . . . . .	1 1
32	827 265	Scheibe 12,5/21,5/2 / washer, shift drum / rondella . . . . .	1 1
33	237 695	Schaltwelle mit Klinke kpl. (bis Motor-Nr. 168.149) / shift shaft with pawl assy. (up to engine serial no. 168.149) / albero cambio (fino a n. motore 168.149) . . . . .	1 1
33	237 696	Schaltwelle mit Klinke kpl. (ab Motor-Nr. 168.150) / shift shaft with pawl assy. (engine serial no. 168.150 and above) / albero cambio (era introdotto da partire del n. motore 168.150) . . . . .	1 1
34	239 830	Klinkenfeder / spring, pawl / molla . . . . .	1 1
35	248 925	Indexhebel kpl. / lever, index / leva indice . . . . .	1 1
36	827 590	Anlaufscheibe 10,1/17/1 / washer / rondella . . . . .	1 1
37	239 820	Indexfeder / spring, index / molla indice . . . . .	1 1
38	247 415	Distanzhülse / distance sleeve / distanziale . . . . .	1 1

Bild Nr. Ill. No. Ill. N.	Teile Nr. Part No. Codice	B e z e i c h n u n g D e s c r i p t i o n D e s c r i z i o n e	126 GS / 126 MG Stück Qty/Qtà	
39	239 640	Haarnadelfeder / spring, transmission actuating lever / molla . . . . .	1	1
40	230 451	O-Ring 13-1,5 (bis Motor-Nr. 168.149) / O-ring (up to engine serial no. 168.149) / anellino gomma (fino a n. motore 168.149) . . . . .	2	2
40	430 110	O-Ring 10-2,7 (ab Motor-Nr. 168.150) / O-ring (engine serial no. 168.150 and above) / anellino gomma (era introdotto da partire del n. motore 168.150) . . .	1	1
41		BP Energrease LS 3 . . . . .	nach Bedarf as required a richiesta	
42	430 110	O-Ring 10-2,7 / O-ring / anellino gomma . . . . .	1	1
43 - 47	248 917	Fußschalthebel kpl. / shift lever assy. / leva cambio compl. . . . .	1	1
43	248 910	Fußschalthebel / shift lever / leva cambio . . . . .	1	1
44	239 770	Hebelfeder / spring / molla . . . . .	1	1
45	240 145	Lagerschraube M6 x 19 / bearing screw / vite . . . . .	1	1
46	248 905	Klapphebel / folding lever / leva piegabile . . . . .	1	1
47	260 545	Klapphebelmuffe / rubber, folding lever / gommino leva piegabile . . . . .	1	1
48	241 930	Zylinderschraube M6 x 20 / cyl. screw / vite a testa cil. . . . .	1	1
49	899 786	Schraubensicherungsmittel LOCTITE blau, 6 cm / means of securing LOCTITE blue 6 c.c. / flacone Loctite blu 6 cc . . . . .	nach Bedarf as required a richiesta	
50	236 952	Kettenrad 15 Z. / sprocket / pignone . . . . .	1	1
	236 951	Kettenrad 14 Z. / sprocket / pignone . . . . .	1	1
	236 950	Kettenrad 13 Z. / sprocket / pignone . . . . .	1	1
51	245 320	Sicherungsblech NA20 / washer, main shaft locking / rondella ferma dado pignone . . . . .	1	1
52	242 605	Sechskantmutter M18 x 1,5 / hex. nut, main shaft / dado pignone . . . . .	1	1

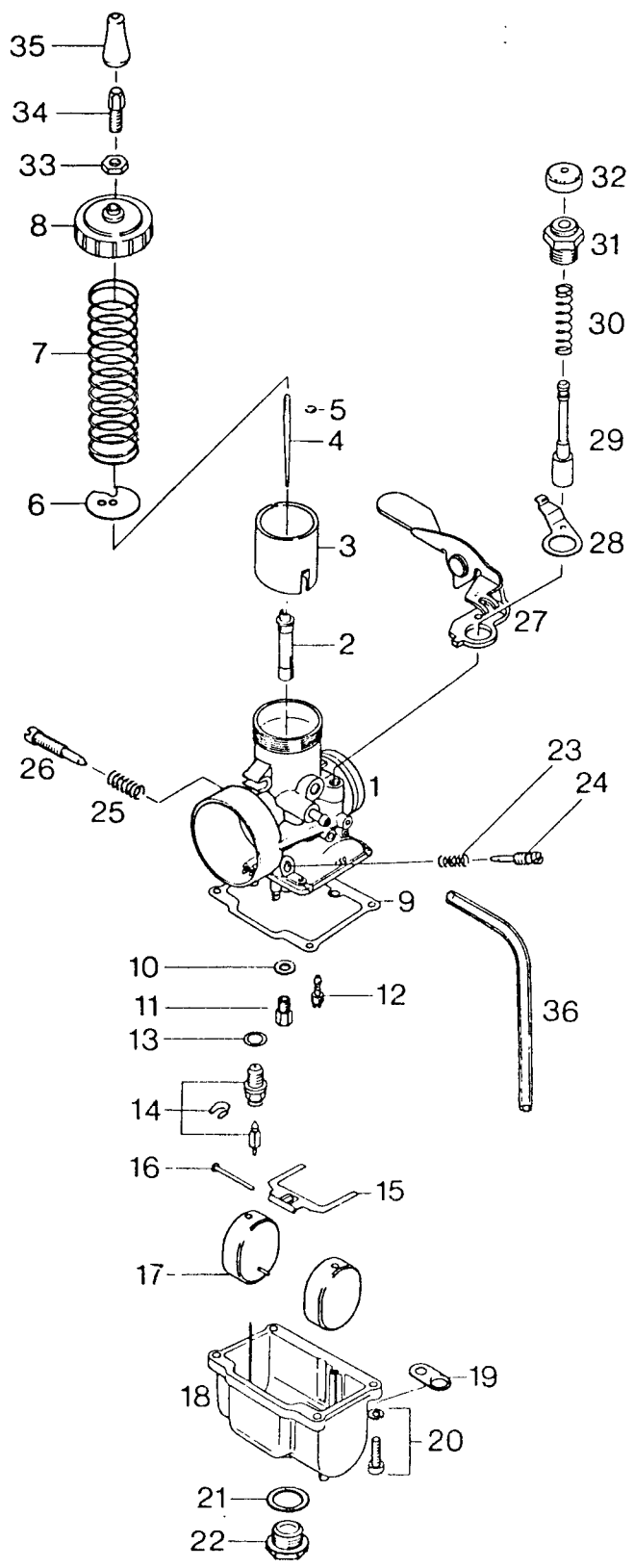

Vergaser  
Carburetor  
Carburatore

Bild Nr. Ill. No. Fig.	Teile Nr. Part No. Ricambi-N.	Bezeichnung Description Descrizione	Stück Qty Qtá.
1 - 34	291 947	MIKUNI-Vergaser VM 34-252 / MIKUNI carburetor assy. / carburatore MIKUNI . . . . .	1
1		Vergasergehäuse kpl. (nicht als Ersatzteil lieferbar, Vergaser kpl. muß verwendet werden) / carburetor housing (not available as spare part, use carburetor assy.) / corpo carburatore . . . . .	1
2	963 955	Nadeldüse 159/Q-2 / needle jet / polverizzatore . . . . .	1
3	963 935	Gasschieber / carburetor piston / valvola gas . . . . .	1
4	963 923	Düsenadel / jet needle / spillo valvola . . . . .	1
5	845 230	Sicherungsscheibe / circlip / seger . . . . .	1
6	963 940	Federplatte / retainer plate / ranella molla valvola gas . . . . .	1
7	938 930	Schieberfeder / spring, carburetor piston / molla valvola gas . . . . .	1
8	963 875	Deckelverschraubung / threaded cap / coperchio valvola . . . . .	1
9	831 895	Dichtung / gasket / guarnizione . . . . .	1
10	827 660	Scheibe 5,3 / washer / rondella . . . . .	1
11	963 881	Hauptdüse 280 / main jet 280 / getto 280 . . . . .	1
	963 976	Hauptdüse 260 / main jet 260 / getto 260 . . . . .	
	963 880	Hauptdüse 270 / main jet 270 / getto 270 . . . . .	
	963 882	Hauptdüse 290 / main jet 290 / getto 290 . . . . .	
	963 883	Hauptdüse 300 / main jet 300 / getto 300 . . . . .	
	963 884	Hauptdüse 310 / main jet 310 / getto 310 . . . . .	
12	963 825	Leerlaufdüse 40 / idler jet 40 / getto minimo 40 . . . . .	1
13	831 905	Dichtring / sealing ring / anello guarnizione . . . . .	1

Bild Nr. Ill. No. Fig.	Teile Nr. Part No. Ricambi-N.	Bezeichnung Description Descrizione	Stück Qty. Qtá.
14	963 847	Nadelventil kpl. / needle valve assy. / valvola a spillo . . . . .	1
15	963 835	Schwimmerhebel / float arm / leva galleggiante . . . . .	1
16	929 770	Stift / pin, float arm / perno leva galleggiante . . . . .	1
17	963 905	Schwimmer / float / galleggiante . . . . .	2
18		Schwimmergehäuse (nicht als Ersatzteil lieferbar) / float chamber (not available as spare part) / vaschetta . . . . .	1
19	261 800	Schlauchlasche / plate / coprighiunto . . . . .	2
20	240 450	Kombischraube M5 x 16 / combined screw / vite . . . . .	4
21	230 900	Dichtring / sealing ring / anello guarnizione . . . . .	1
22	963 967	Ablaßschraube / plug screw / vite . . . . .	1
23	938 950	Druckfeder / spring, air regulating screw / molla vite aria . . . . .	1
24	963 860	Luftregulierschraube / air regulating screw / vite aria . . . . .	1
25	938 940	Druckfeder / spring, adjustment screw / molla vite minimo . . . . .	1
26	963 850	Stellschraube / adjustment screw / vite minimo . . . . .	1
27	261 810	Handhebel kpl. / choke lever assy. / dispositivo starter completo . . . . .	1
28	239 840	Blattfeder / spring / molla ballestra . . . . .	1
29	963 795	Startkolben mit Dichtung / starting piston w. gasket / pistoncino starter con guarnizione . . . . .	1
30	938 925	Druckfeder / spring, starting piston / molla pistoncino starter . . . . .	1
31	963 817	Startgehäuse / housing, starting piston / corpo pistoncino starter . . . . .	1
32	260 495	Gummikappe / rubber cap / gommino tappo corpo pistoncino aria . . . . .	1

Bild Nr. Ill. No. Fig.	Teile Nr. Part No. Ricambi-N.	Bezeichnung Description Descrizione	Stück Qty. Qtá.
33	942 546	SK-Mutter M6 x 0,75 / hex. nut / dado registro filo gas . . . . .	1
34	241 445	Stellschraube M6 x 0,75 / adjustment screw / registro filo gas . . . . .	1
35	960 980	Gummitülle / rubber grommet / cappuccio registro filo gas . . . . .	1
36	260 581	Entlüfterschlauch 120 mm / vent line / tubo dell'aria . . . . .	2

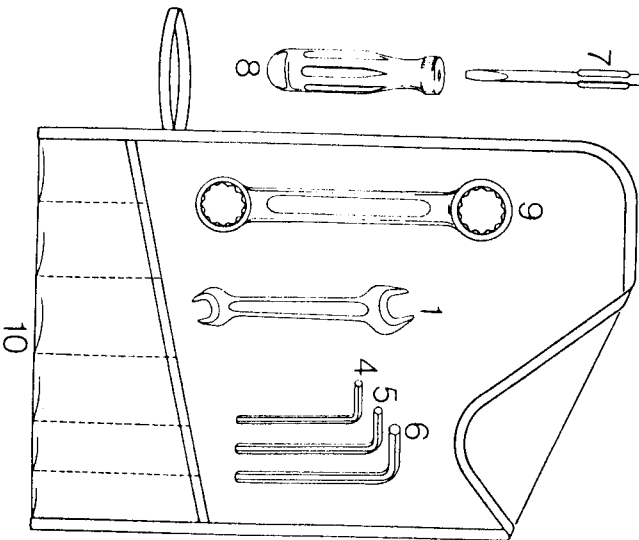
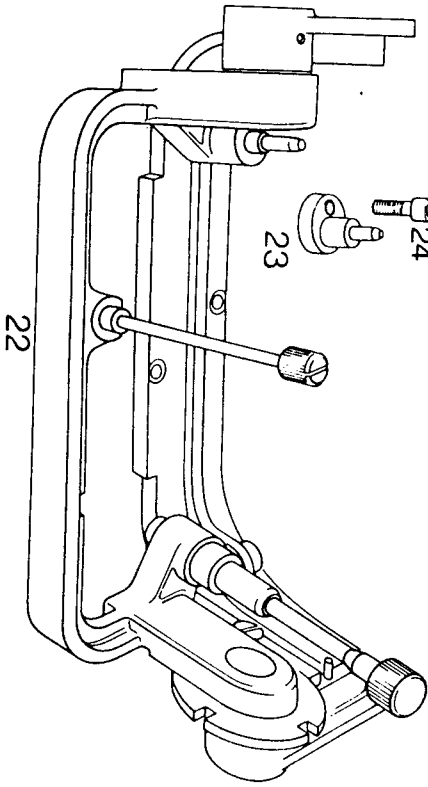
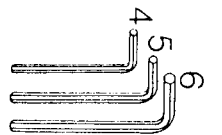
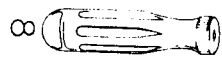
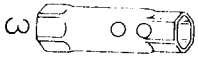
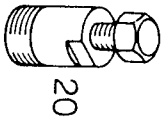
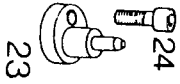
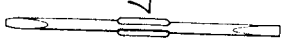
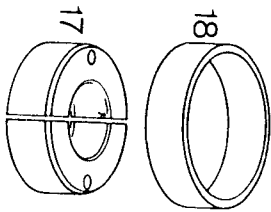
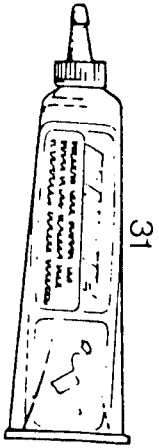
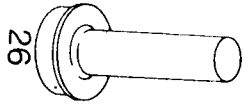
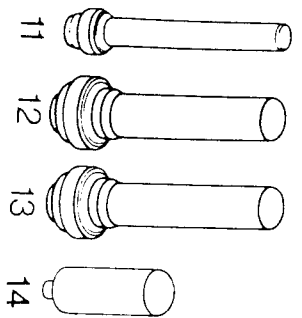
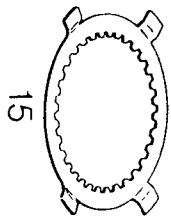
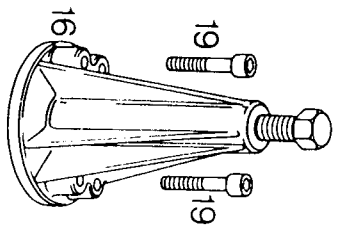
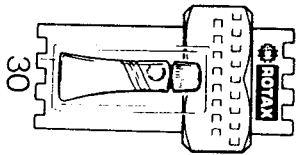
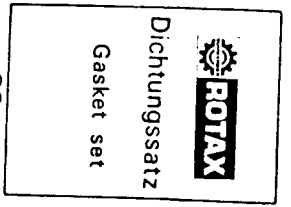
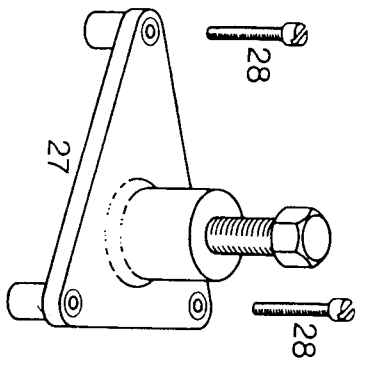

Werkzeug / Tools / Attrezzi

Bild Nr. Ill. No. Ill. N.	Teile Nr. Part No. Codice	B e z e i c h n u n g D e s c r i p t i o n D e s c r i z i o n e	Stück Qty Qtà
1 - 10	277 780	Werkzeugsatz kpl. / tool kit, owners / truss ferri . . . . .	1
1	276 065	Doppelmaulschlüssel 10/13 mm / fork wrench / chiave fissa . . . . .	1
2	876 220	Steckschlüssel 11/13 mm / socket wrench / chiave a tubo . . . . .	1
3	277 411	Steckschlüssel 17/21 mm / socket wrench / chiave a tubo . . . . .	1
4	277 790	Sechskant-Stiftschlüssel 4 / wrench, int. hex. screw / chiave a brugola . . . . .	1
5	876 360	Sechskant-Stiftschlüssel 5 / wrench, int. hex. screw / chiave a brugola . . . . .	1
6	277 810	Sechskant-Stiftschlüssel 6 / wrench, int. hex. screw / chiave a brugola . . . . .	1
7	277 830	Schraubenziehereinsatz / insert for screw driver / inserto cacciavite . . . . .	1
8	277 840	Schraubenziehergriff / grip for screw driver / manico cacciavite . . . . .	1
9	277 825	Ringschlüssel 22 x 24 / ring wrench / chiave a stella . . . . .	1
10	876 195	Werkzeugtasche schwarz / tool bag / busta per attrezzi . . . . .	1
11	277 850	Montagestempel zur Montage des WD-Ringes 230 355 / oil seal insertion jig, to mount oil seal 230 355 / attrezzo . . . . .	1
12	277 861	Montagestempel zur Montage des WD-Ringes 230 395 für MS / oil seal insertion jig, to mount oil seal 230 395 / attrezzo . . . . .	1
12	277 866	Montagestempel zur Montage des WD-Ringes 230 395 für KS / oil seal insertion jig, to mount oil seal 230 395 / attrezzo . . . . .	1
13	277 870	Montagestempel zur Montage des WD-Ringes 230 421 / oil seal insertion jig, to mount oil seal 230 421 / attrezzo . . . . .	1



Bild-Nr. Ill. No. Ill. N.	Teile Nr. Part No. Codice	B e z e i c h n u n g D e s c r i p t i o n D e s c r i z i o n e	Stück Qty Qtà
14	876 510	Montagestempel zur Montage des WD-Ringes 831 740 / oil seal insertion fig. to mount oil seal 831 740 / attrezzo . . . . .	1
15	277 887	Mitnehmerfixierung / clutch hub locking tool / attrezzo bloccaggio frizione . . . . .	1
16	876 296	Abzieher kpl. / puller assy. for bearing on crankshaft / estrattore . . . . .	1
17	277 890	Ringhälfte / ringhalf for puller / attrezzo	2
18	977 480	Ring/ ring for puller / attrezzo . . . . .	1
19	840 680	Zylinderschraube M6 x 40, int. hex. screw w. int. hex. / brugola fissaggio attrezzo . . . . .	2
20	276 807	Abzieher kpl. M26 x 1,5 für 180 Nm / puller assy. for flywheel / estrattore volante . . . . .	1
20	276 805	Abzieher kpl. M27 x 1,5 für 226 Nm / puller assy. for flywheel / estrattore volante . . . . .	1
21	276 790	Schutzkappe / protection cap / coperchio protettivo . . . . .	1
22	277 915	Montagebock / assembly trestle / attrezzo supporto motore . . . . .	1
23	276 750	Montagebockeinsteck kpl. / insert for assembly trestle assy. / inserimento attrezzo supporto motore . . . . .	1
24	241 930	Zyl. Schraube M6 x 30 / cyl. screw / brugola	1
25	241 965	Fixierschraube M8 x 30 / locking screw for crankshaft / fermo bloccaggio sabbia motore	1
26	276 200	Montagestempel kpl. für die Montage des 260 390 / plastic ring for the mag. magneto side / attrezzo montaggio anelli reflon per cuscinetti . . . . .	1
27	276 795	Abzieherplatte für Gehäuse des Motors / plate for puller, crankcase half / estrattore motore arter . . . . .	1
28	241 820	Zylinderschraube M6 x 30 / cyl. screw / brugola . . . . .	4
29	234 104	Dichtungssatz kpl. / seal kit / serie guarnizione	1
30	899 504	Schraubensicherungsmittel / means of securing screw / flacone Loctite . . . . .	1 Bedarf as requ. richiesta
31	899 501	Flanschdichtung Spezial / special seal weiß / LOCTITE seal white / flacone Loctite . . . . .	1 Bedarf as requ. richiesta